

GREENCO
 CORPORATION

CABLE-TROL

5688 W. CRENSHAW ST.
 TAMPA, FL. 33634-3013
 PH: (813) 882-4400
 FAX: (813) 888-6688

MODELS 15 ,20 ,25 ,32, 40, 50, AND 20P & 25P

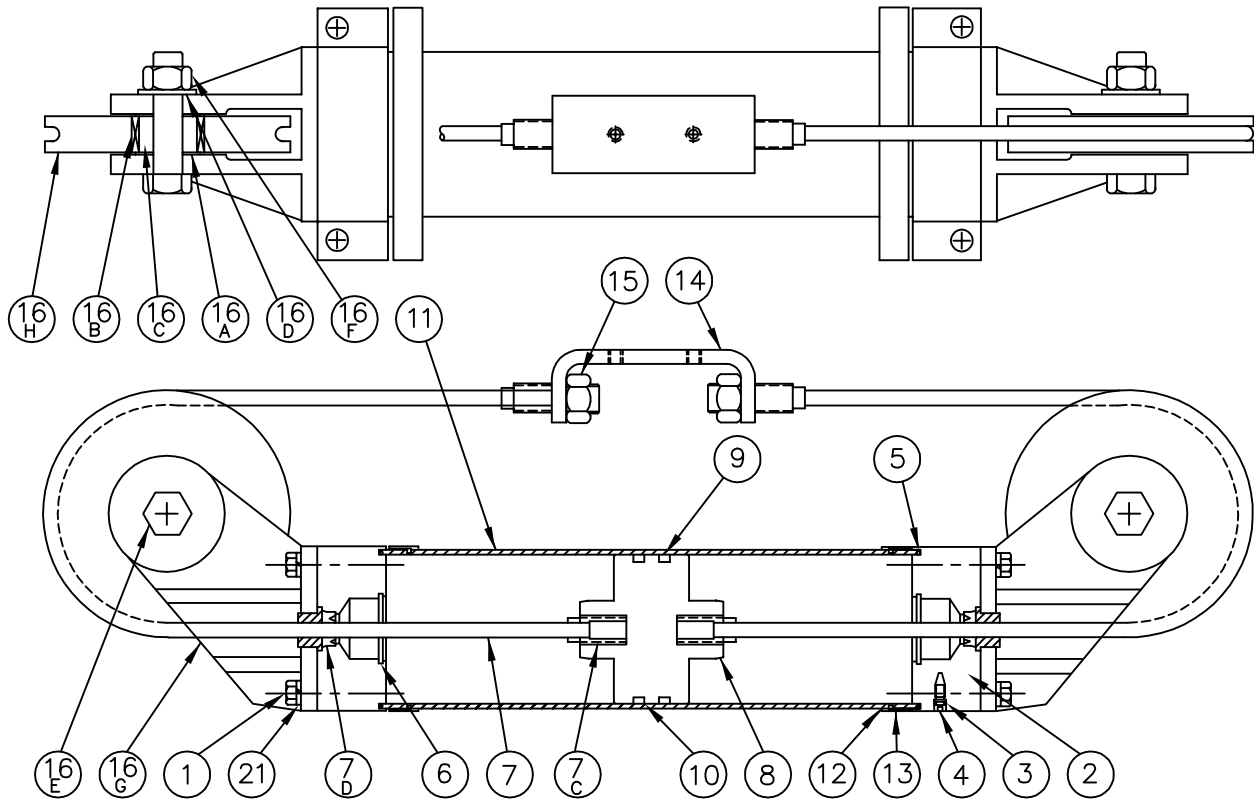

WHEN ORDERING PARTS, PLEASE SPECIFY COMPLETE MODEL AND SERIAL NUMBER

PARTS LISTS

DESCRIPTION	PART NO.	QTY.	DESCRIPTION	PART NO.	QTY.
1. HEAD BOLT	3XX-00100	(8)	16A. WASHER, THRUST	5XX-01610	(4)
2. FRONT HEAD	1XX-0020+	(2)	16B. BEARING	5XX-01620	(2)
* 3. NEEDLE O-RING	4XX-00300	(2)	16C. SHAFT	1XX-01630	(2)
4. CUSH. NEEDLE	1XX-00400	(2)	16D. WASHER	5XX-01640	(2)
* 5. HEAD O-RING	4XX-00500	(2)	16E. BOLT	3XX-01650	(2)
* 6. CUSH. SEAL	4XX-00600	(2)	16F. NUT	3XX-01660	(2)
* 7. CABLE S/A	9XX-XX000	(2)	16G. BRACKET	1XX-01670	
* 7C. PISTON SCREW	1XX-00730	(2)	16H. SHEAVE	1XX-01680	(2)
* 7D. CABLE SEAL	4XX-00740	(2)	21. LOCK WASHER	3XX-00130	(8)
8. PISTON	1XX-00800	(1)			
9. SLYDRING (MDL. 15)	515-00900	(2)			
* 10. U-CUP	4XX-01000	(2)			
11. TUBE		(1)			
12. HEAD FLANGE	1XX-01200	(2)			
13. RET. RING	3XX-01300	(2)			
14. C-TROLLEY	1XX-01400	(1)			
15. NUT	3XX-01500	(2)			

MODELS 20P,50,60,80 ONLY

16B. BALL BRG.	5XX-01620	(4)
16E. RET. RING	3XX-01690	(4)

* 20 REPAIR KIT (1 PAIR OF EACH PART)

+ LAST DIGIT DENOTES PORT POSITION