

AIR/OIL TANK

FEATURES & DIMENSIONS

GREENCO

LEADERS IN RODLESS CYLINDERS™

HOW TO ORDER

1. Refer to Table 1, on page 5 to find effective area (square inch) of cylinder.
2. Multiple effective area by stroke of cylinder to determine volume.
3. **IMPORTANT:** Multiply area by 1.5 **safety factor.**
4. Select Air/Oil tank capacity closest to volume.
See capacity chart below.

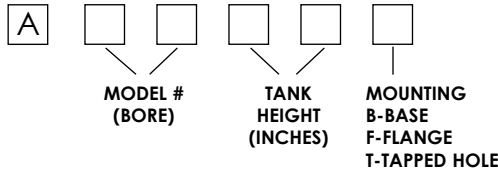

EXAMPLES:

CD2511A
 (Effective area of Model 25)4.8597
 (Stroke)x 11
 53.45
 (Safety Factor.....x 1.5
 80.19

Base your selection on space requirement and port size (for high speed).

Depending on space available, the customer could select A2517T, A3210T, A4007T, A5004T or A6003T.

OPTIONAL BASE & FLANGE MOUNT

BORE	C	FB	FH	J	RE	SB	THK.	TF	TS	UF	US
2.50	1.250	3/8	3/8	1	2.190	7/16	3/8	3 7/8	3 3/4	4 5/8	4 1/2
3.25	1.500	7/16	5/8	1 1/4	2.760	9/16	1/2	4 11/16	4 3/4	5 1/2	5 3/4
4.00	2.062	7/16	5/8	1 1/4	3.320	9/16	1/2	5 7/16	5 1/2	6 1/4	6 1/2
5.00	2.688	9/16	5/8	1 1/4	4.100	5/8	3/4	6 5/8	6 7/8	7 5/8	8 1/4
6.00	3.250	9/16	3/4	1 1/2	4.880	3/4	1	7 5/8	7 7/8	8 5/8	9 1/4
8.00	4.500	N/A	N/A	1 1/2	N/A	3/4	1	N/A	9 7/8	N/A	11 1/4

Tolerance on Overall Height: ± 1/16" On Fractions
 ± .010 On 3 Place Decimals

Dimensions in inches

OPTIONAL BASE MOUNT (TYP. TOP & BOTTOM)

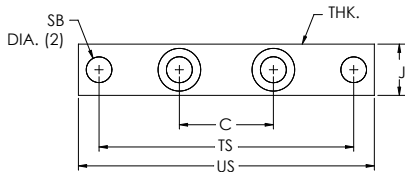

OPTIONAL FLANGE MOUNT (NOTE: FLANGE ADDS TO OVERALL HEIGHT)

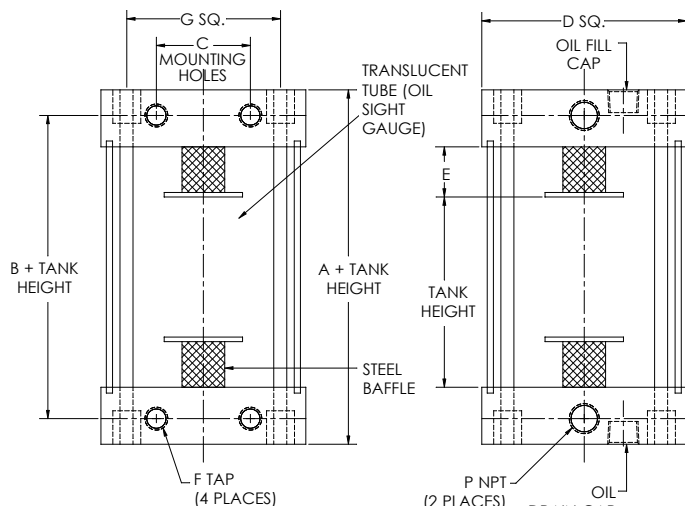
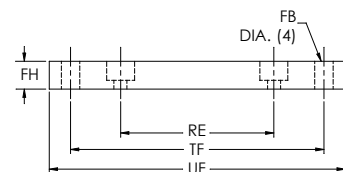

TRANSLUCENT TUBING DESIGN

**NOTE: 200° F
 MAX. OPERATING
 TEMPERATURE
 150 PSI MAX.**



Greenco's air over oil tank is the ideal answer for your power requirements where smooth, even hydraulic action is required. This lightweight, compact unit is easily installed on any existing or new application. Years of worry-free, inexpensive operation are virtually guaranteed, because there are no moving parts.

TAPPED HOLE MOUNT (STANDARD)

BORE	VOLUME (PER IN.)	A	B	C	D	E	F	G	P NPT
2.50	4.91 cu. in.	3 5/32	2 9/32	1.250	3.000	1 1/8	3/8-16" x .625"	2.190	3/8
3.25	8.30 cu. in.	3 17/32	2 13/32	1.500	3.750	1	1/2-13" x .750"	2.760	1/2
4.00	12.57 cu. in.	3 17/32	2 13/32	2.062	4.500	1	1/2-13" x .750"	3.320	1/2
5.00	19.64 cu. in.	3 17/32	2 13/32	2.688	5.500	1	5/8-11" x 1.00"	4.100	1/2
6.00	28.27 cu. in.	4 1/32	2 21/32	3.250	6.500	1	3/4-10" x 1.125"	4.880	3/4
8.00	50.26 cu. in.	4 1/32	2 21/32	4.500	8.500	1	3/4-10" x 1.125"	6.440	3/4

NOTE: Flange & base mounting available at extra cost.
 Dimensions in inches

USABLE OIL CAPACITY CHART (cu. in.)

TANK HEIGHT WITH USEABLE OIL CAPACITY IN CUBIC INCHES	MODEL NUMBERS					
	A-25	A-32	A-40	A-50	A-60	A-80
	TANK BORE SIZE (INCHES)					
	2 1/2"	3 1/4"	4"	5"	6"	8"
1"	5	8	12	20	28	50
2"	10	16	25	39	56	100
3"	15	25	37	59	84	150
4"	19	33	50	78	112	199
5"	24	41	62	98	140	249
6"	29	49	75	117	168	299
7"	34	58	87	137	197	349
8"	39	66	100	156	225	399
9"	44	74	112	176	253	449
10"	48	82	125	195	281	499
11"	53	90	137	215	309	549
12"	58	99	149	234	337	598
13"	63	107	162	254	365	648
14"	68	115	174	273	393	698
15"	73	123	187	293	421	748
16"	78	132	199	312	449	798
17"	82	140	212	332	477	848

NOTE: TANK HEIGHTS ARE NOT LIMITED TO 17". TANK HEIGHTS UP TO 10 FT. ARE POSSIBLE.