

GREENCO
 CORPORATION

CABLE-TROL

5688 W. CRENSHAW ST.
 TAMPA, FL. 33634-3013
 PH: (813) 882-4400
 FAX: (813) 888-6688

MODELS CS15 CS20 CS25 CS32 CS40 CS50 CS20P AND CS25P

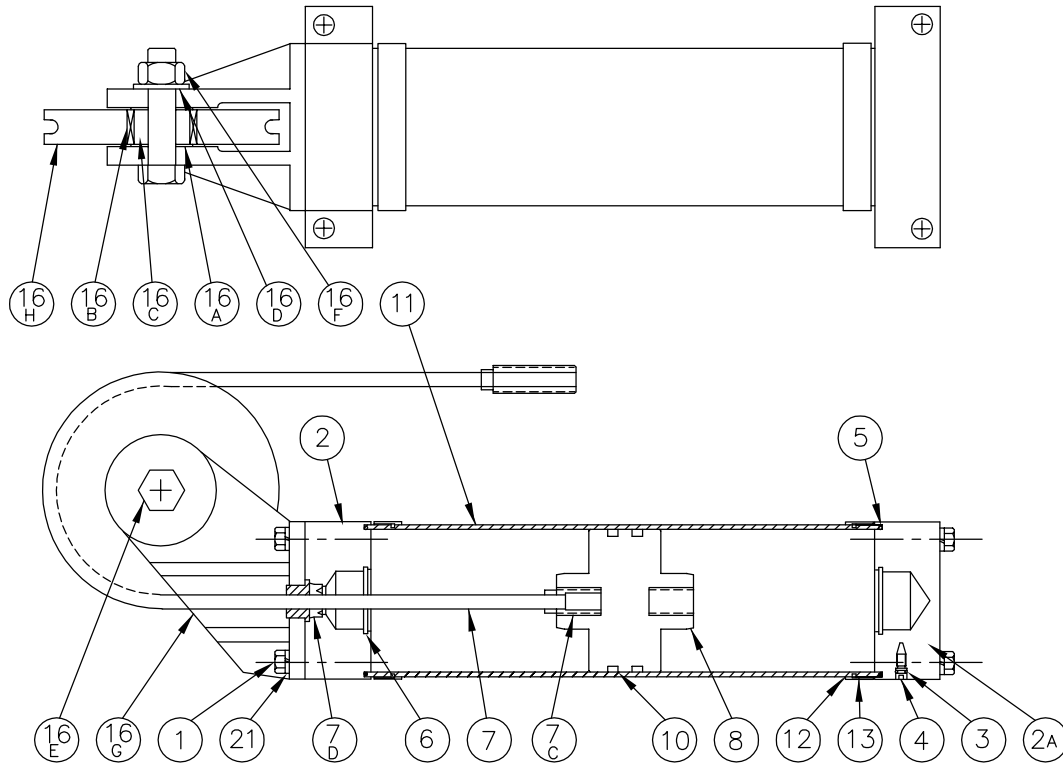

WHEN ORDERING PARTS, PLEASE SPECIFY COMPLETE MODEL AND SERIAL NUMBER

PARTS LISTS

DESCRIPTION	PART NO.	QTY.	DESCRIPTION	PART NO.	QTY.
1. HEAD BOLT	3XX-00100	(8)	16A. WASHER, THRUST	5XX-01610	(2)
2. FRONT HEAD	1XX-0020+	(1)	16B. BEARING	5XX-01620	(1)
2A. REAR HEAD	1XX-0020=	(1)	16C. SHAFT	1XX-01630	(1)
* 3. NEEDLE O-RING	4XX-00300	(2)	16D. WASHER	3XX-01640	(1)
4. CUSH. NEEDLE	1XX-00400	(2)	16E. BOLT	3XX-01650	(1)
* 5. HEAD O-RING	4XX-00500	(2)	16F. NUT	3XX-01660	(1)
* 6. CUSH. SEAL	4XX-00600	(2)	16G. BRACKET	1XX-01670	(1)
* 7. CABLE S/A	9XX-XX000	(1)	16H. SHEAVE	1XX-01680	(1)
* 7C. PISTON SCREW	1XX-00730	(1)	21. LOCK WASHER	3XX-00130	(8)
* 7D. CABLE SEAL	4XX-00740	(1)			
8. PISTON	1XX-00800	(1)			
* 10. U-CUP	4XX-01000	(2)			
11. TUBE		(1)			
12. HEAD FLANGE	1XX-01200	(2)			
13. RET. RING	3XX-01300	(2)			

MODELS 20P,50,60,80 ONLY
 16B. BALL BRG. 5XX-01620 (4)
 16E. RET. RING 3XX-01690 (4)

* 20 REPAIR KIT (1 PAIR OF EACH PART)
 + LAST DIGIT DENOTES PORT POSITION
 = LAST DIGIT DENOTES PORT POSITION PLUS 5